

PREVECTRON 3 S60

EARLY STEAMER EMISSION AIR TERMINAL (ESE)

Reference	P1543	
Characteristics		
Efficiency	ΔT	60 μs
Standard deviation ESE / Single Rod	σ	$\sigma_{PDA} < 0,4 \sigma_{PTS}$
Lightning current withstanding test (10/350 μs)	I_{imp}	100kA (normative test)
Max. current withstanding test	I_{max}	207 kA (Unicamp)
Net Weight	P	3.900 kg
Operating principles		
Detection of download leader	Continuous measuring of electric field gradient ($\Delta E/\Delta t$)	
Upward streamer development conditions	Patented OPTIMAX® technology optimizing the streamer development conditions	
Upward streamer emission	Sparking by High Voltage Impulses	
Internal circuits	6 independent and synchronised modules	
Central rod	Full electrical continuity 315 mm ² section – Nickel plated Copper	
Metal housing	Stainless Steel 316, Electromagnetic shielding	
On-site testing capabilities	Proprietary tester	
Maintenance	Replaceable modules	
Warranty	5 years	
Mechanical specifications		
Fixing on pole	M20 Thread	
Down conductor connection	Specific clamp ref P6500 (included)	
Packaging		
Dimensions	438 x 228 x 220 mm	
Contents	Prevectron®3, Down conductor clamp, Hex key	
Gross Weight	5.650 kg	
Environmental sustainability	100% recyclable	
Certifications		
NF C 17 102:2011, Annexe C	Bureau Veritas certificate N°6275241/2/1/1	
Qualifoudre	Ineris certificate N° N°051166662001	
ISO 9001 : 2008	Bureau Veritas certificate N°FR018755-1	
CE Marking	Attest report N°IND-CE-21092015-A	
Underwriter Laboratories (UL)	UL Certified E478687	
Rostechnadzor (RTN Russia)	N° RRS 00-05003	
Eco -label	AVNIR/In Planet	

PREVECTRON 3® S60



Modular design

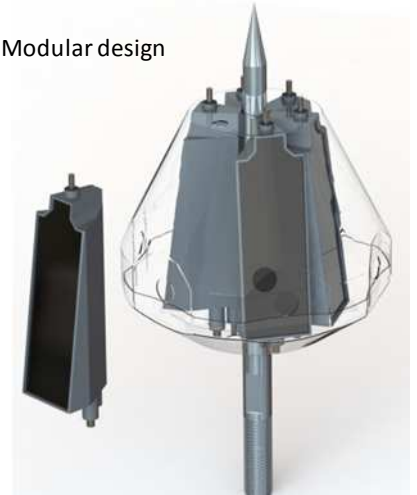

Dimensions (mm)

